

K76

Specifications 1/6

Incremental Type (Hollow shaft,through hole)

- Feature: Thin type, sturdy and durable, optional various output mode, long service life, low price, etc
- Application: servo motor, textile industry, packing machinery, production line, etc, for automation control
- External dimensions: external diameter $\phi 76.5\text{mm}$, thickness 37mm, diameter of shaft $\phi 18\text{mm}$; $\phi 20\text{mm}$; $\phi 22\text{mm}$; $\phi 25\text{mm}$; $\phi 28\text{mm}$; $\phi 30\text{mm}$ optionally
- Resolution: up to 32768P/R
- Supply voltage: DC5V; DC8-30V
- Protection: IP50
- Cable length: 1000mm
- Weight: about 360g

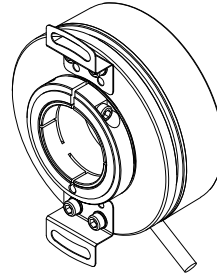

K76-J
clamping ring at prior
(BQ)

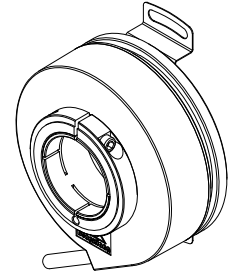

K76-J
clamping ring at rear
(B)

Model Guide

- Model form (filled required parameters in the box as following)
- Must choose supply voltage: DC5V; DC8-30V
- Must choose clamping ring at prior (BQ) or clamping ring at rear (B) when choosing diameter of shaft
- The installation of leaf spring please refer to Page 5

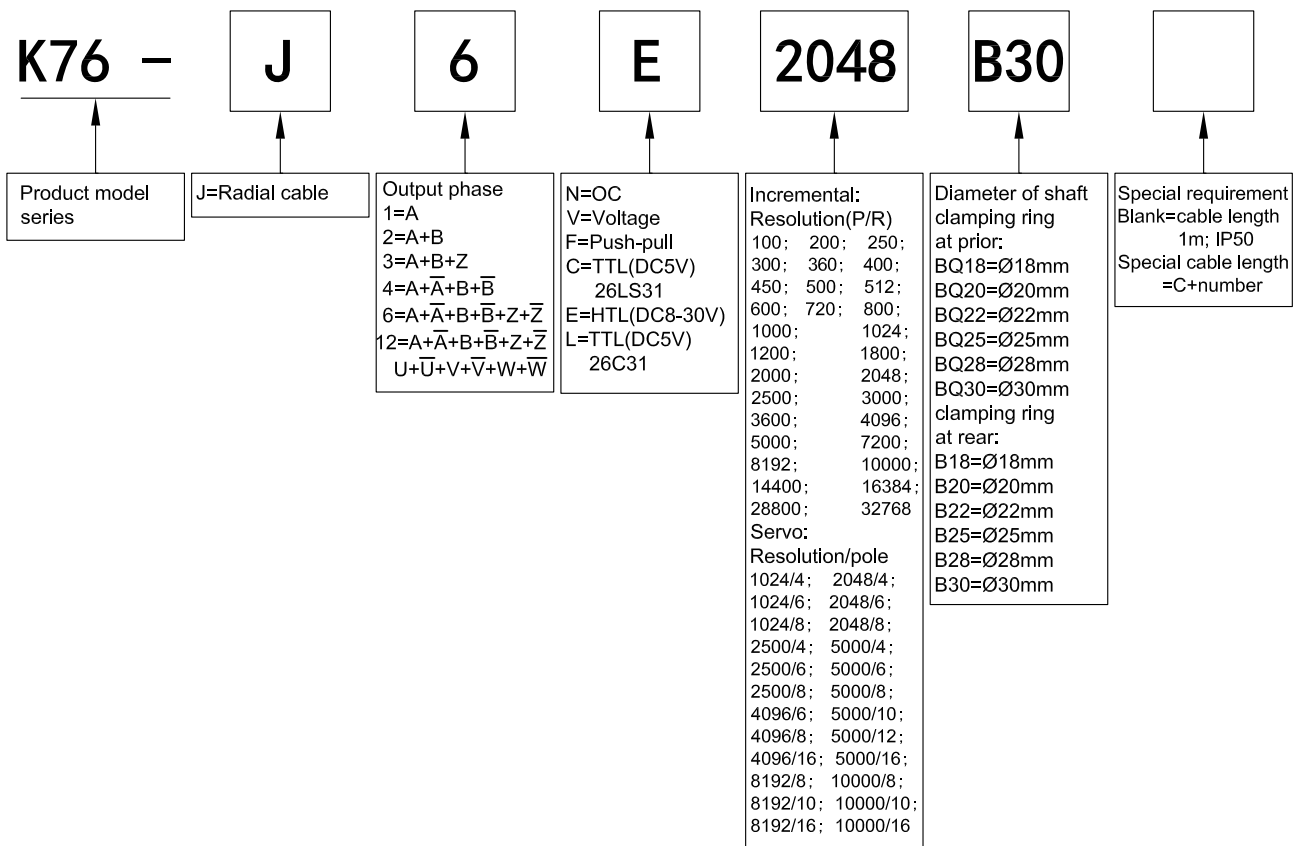

K76 Specifications 2/6

Output Mode

Output type	Output circuit	Output wave form	Connection
OC		<p> $a.b.c.d = \frac{T}{4} \pm \frac{T}{8}$ Phase A is ahead of B by $\frac{T}{4} \pm \frac{T}{8}$, rotation direction CW (Viewing from shaft end, direction is clockwise rotation) CW direction \rightarrow </p>	0=GND 1=red=DC5V; DC8-30V 2=black=OV 3=white=A 4=green=B 5=yellow=Z
Push-Pull		<p> $a.b.c.d = \frac{T}{4} \pm \frac{T}{8}$ Phase A is ahead of B by $\frac{T}{4} \pm \frac{T}{8}$, rotation direction CW (Viewing from shaft end, direction is clockwise rotation) CW direction \rightarrow </p>	
Voltage		<p> $a.b.c.d = \frac{T}{4} \pm \frac{T}{8}$ Phase A is ahead of B by $\frac{T}{4} \pm \frac{T}{8}$, rotation direction CW (Viewing from shaft end, direction is clockwise rotation) CW direction \rightarrow </p>	
TTL HTL		<p> $a.b.c.d = \frac{T}{4} \pm \frac{T}{8}$ Phase A is ahead of B by $\frac{T}{4} \pm \frac{T}{8}$, rotation direction CW (Viewing from shaft end, direction is clockwise rotation) CW direction \rightarrow </p>	

K76 Specifications 3/6

● Output Mode

Output type	Output circuit	Output wave form	Connection
TTL		<p style="margin-left: 20px;"> $a, b, c, d = \frac{T}{4} \pm \frac{T}{8}$ $e = T \pm \frac{T}{2}$ f: center of phase Z to rise point of phase U, that is $\pm 0.3^\circ$ </p> <p style="margin-left: 20px;"> CCW direction \rightarrow (Viewed from shaft end when installing) </p> <p style="margin-left: 20px;"> A, B, Z, U, V, W $\bar{A}, \bar{B}, \bar{Z}, \bar{U}, \bar{V}, \bar{W}$ </p>	<p>0=shielding=GND 1=red=DC5V 2=black=OV 3=white=A 4=green=B 5=yellow=Z 6=white/black=\bar{A} 7=green/black=\bar{B} 8=yellow/black=\bar{Z} 9=blue=U 10=gray=V 11=pink=W 12=blue/black=\bar{U} 13=gray/black=\bar{V} 14=pink/black=\bar{W}</p>

■ Electrical Characteristics

Parameter Item	Output type	OC		Voltage		Push-pull		TTL(26LS31)	TTL(26C31)	HTL(HD7)
		Supply voltage		DC+5V±5%; DC8V-30V±5%						DC+5V±5%
Consumption current		100mA Max						120mA Max		
Allowable ripple		≤3%rms								
Top response frequency		100KHz						200KHz		300KHz
Output capacity	Output current	Input	≤30mA	Load resistance 2.2K	≤30mA	≤±20mA		≤±50mA		
		Output	—		≤10mA					
	Output voltage	"H"	—	—	≥[(Supply voltage)-2.5V]	≥2.5V		≥V _{CC} -3 V _{DC}		
		"L"	≤0.4V	≤0.7V(less than 20mA)	≤0.4V(30mA)	≤0.5V		≤1V V _{DC}		
Load voltage	≤DC30V		—		—					
Rise & Fall time		Less than 2us(cable length: 2m)				Less than 1us(Cable length: 2m)		≤100ns		
Insulation strength		AC500V 60s								
Insulation resistance		10MΩ								
Mark to space ratio		45% to 55%								
Phase shift between A & B		90°±10° (frequency in low speed)								
		90°±20° (frequency in high speed)								
Origin motion		Low level available	High level available	Low level available	—					
GND		not connect to encoder								

■ Mechanical Characteristics

Shaft	Ø18mm; Ø20mm; Ø22mm; Ø25mm; Ø28mm; Ø30mm(stainless steel)
Starting torque	Less than 80×10^{-3} N·m
Inertia moment	Less than 100×10^{-6} kg·m ²
Shaft load	Radial 70N; Axial 50N
Slew speed	≤3000 rpm
Shell	Aluminium alloy
Weight	about 360g

■ Environmental Specifications

Environmental temperature	Operating: -20~+85°C(repeatable winding cable: -10°C); Storage: -25~+90°C
Environmental humidity	Operating and storage: 35~85%RH(noncondensing)
Vibration(endure)	Amplitude 0.75mm, 5~55Hz, 2h for X,Y,Z direction individually
Shock(endure)	1960m/s ² , 11ms three times for X,Y,Z direction individually
Protection	IP50

K76 Specifications 5/6

■ Basic Dimensions

- clamping ring at prior(BQ)

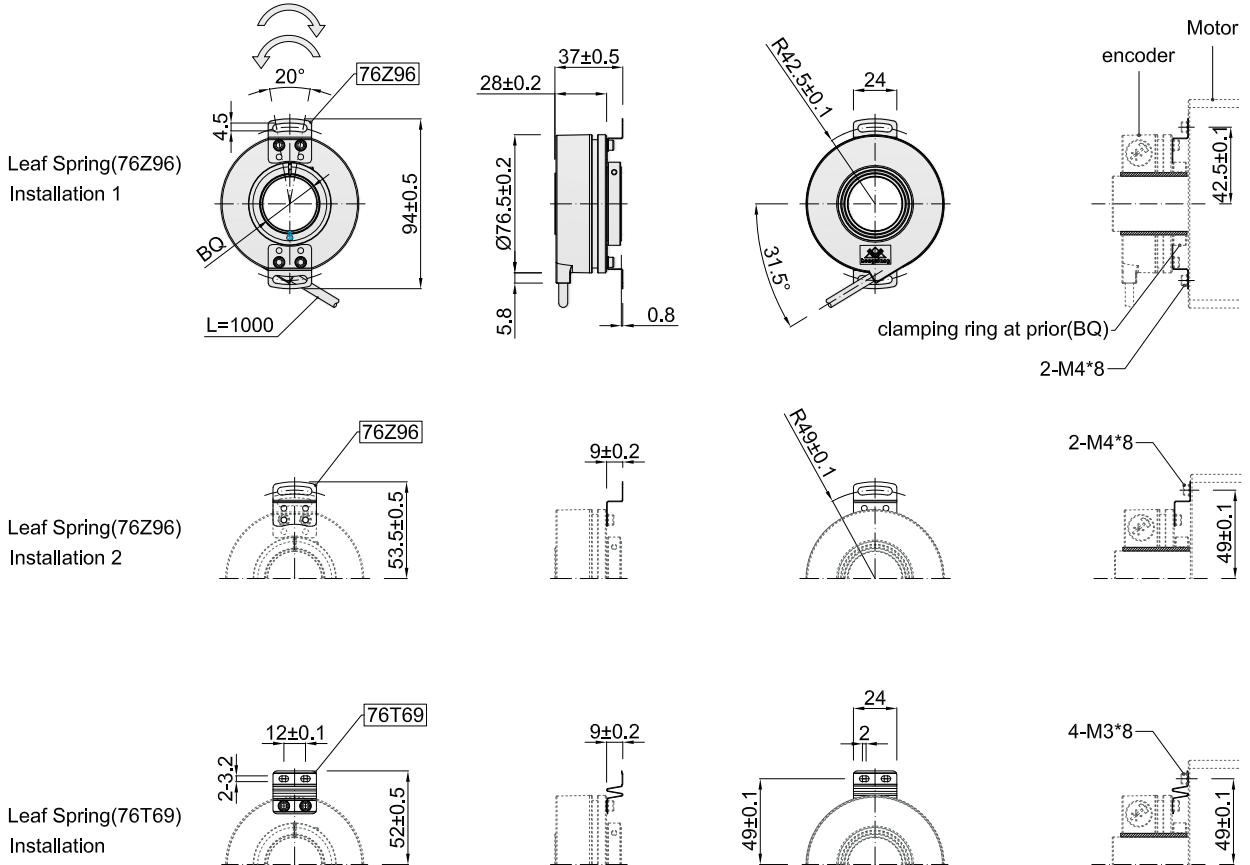

- clamping ring at rear(B)

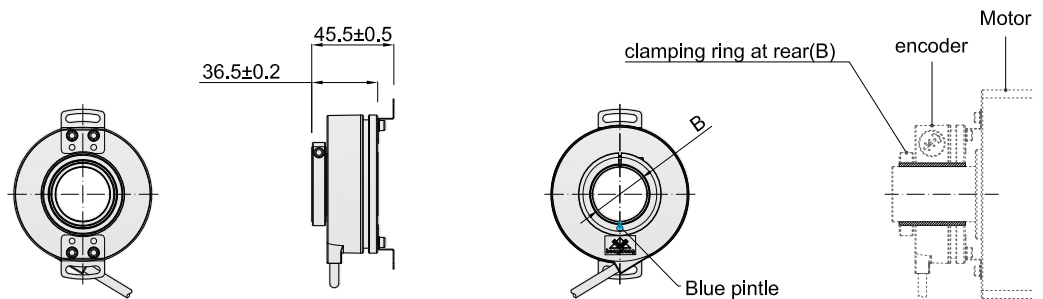

Unit: mm

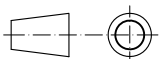

76Z96 = Leaf Spring

76T69 = Leaf Spring(used for low-precision high-pulse, unavailable with UVW signal)

= The shaft rotary direction for encoder without UVW signal

= The shaft rotary direction for encoder with UVW signal

Blue pintle:

This unique designed blue pintle is used to synchronize the rotation between the hoop and the shaft, which is easier to adjust the mechanical zero position

K76

Specifications 6/6

Assembling requirement

- clamping ring at prior(BQ)

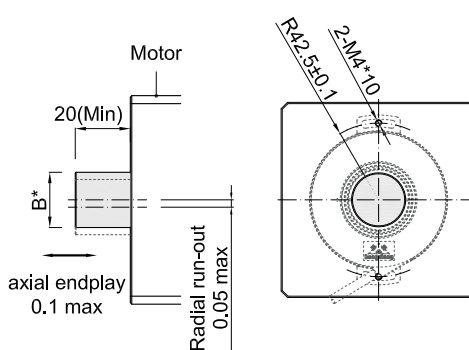
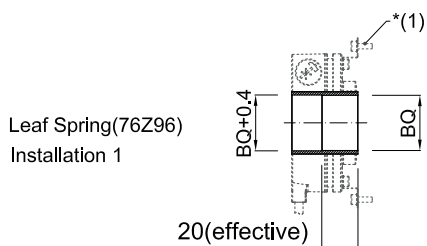

BQ	B*
$\varnothing 18^{G7}_{(+0.028/+0.007)}$	$\varnothing 18_{g6}^{(-0.007/-0.020)}$
$\varnothing 20^{G7}_{(+0.028/+0.007)}$	$\varnothing 20_{g6}^{(-0.007/-0.020)}$
$\varnothing 22^{G7}_{(+0.028/+0.007)}$	$\varnothing 22_{g6}^{(-0.007/-0.020)}$
$\varnothing 25^{G7}_{(+0.028/+0.007)}$	$\varnothing 25_{g6}^{(-0.007/-0.020)}$
$\varnothing 28^{G7}_{(+0.028/+0.007)}$	$\varnothing 28_{g6}^{(-0.007/-0.020)}$
$\varnothing 30^{G7}_{(+0.028/+0.007)}$	$\varnothing 30_{g6}^{(-0.007/-0.020)}$

B* Motor shaft diameter tolerance

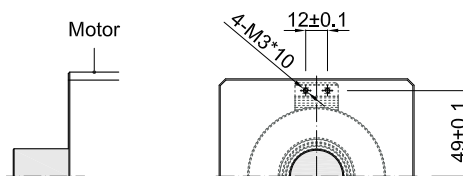
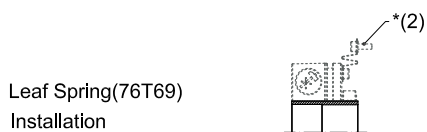
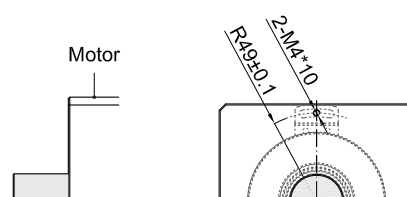
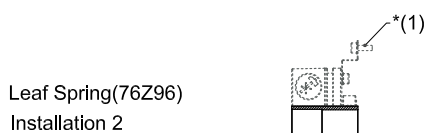

- clamping ring at rear(B)

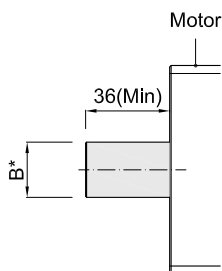
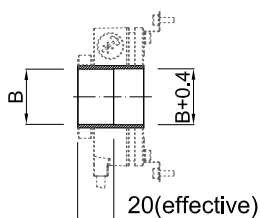

B	B*
$\varnothing 18^{G7}_{(+0.028/+0.007)}$	$\varnothing 18_{g6}^{(-0.007/-0.020)}$
$\varnothing 20^{G7}_{(+0.028/+0.007)}$	$\varnothing 20_{g6}^{(-0.007/-0.020)}$
$\varnothing 22^{G7}_{(+0.028/+0.007)}$	$\varnothing 22_{g6}^{(-0.007/-0.020)}$
$\varnothing 25^{G7}_{(+0.028/+0.007)}$	$\varnothing 25_{g6}^{(-0.007/-0.020)}$
$\varnothing 28^{G7}_{(+0.028/+0.007)}$	$\varnothing 28_{g6}^{(-0.007/-0.020)}$
$\varnothing 30^{G7}_{(+0.028/+0.007)}$	$\varnothing 30_{g6}^{(-0.007/-0.020)}$

B* Motor shaft diameter tolerance

Unit: mm

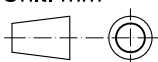

Note:

- *(1): Inner hexagon screw M4*8 with flat gasket and spring ring is recommended to use
- *(2): Inner hexagon screw M3*8 with flat gasket and spring ring is recommended to use

About vibration

Vibration act on encoder always cause wrong pulse ,so we should pay attention to working place. More pulse per revolution , narrower groovy spacing of grating ,more effect to encoder by vibration,when rev is low or stop , vibration act on shaft or main body would cause grating vibrating ,so encoder might make wrong pulse.